

## HSC 5000 SERIES

SCREW COUPLINGS FOR HIGH PRESSURE PULSE APPLICATIONS.

**CONNECT & DISCONNECT UNDER PRESSURE**

### INTRODUCTION

Holmbury HSC 5000 Series of heavy duty, high-pressure, hydraulic, screw couplings are designed to withstand the most severe pressure pulse applications, where other couplings suffer rapid failure. They can be connected and disconnected under pressure.

### APPLICATIONS

Excavator hammer attachments, rock crushers, test rigs and all other applications involving intense pressure pulses.

### ADVANTAGES

- ★ Screw thread connection eliminates Brinelling
- ★ Connects and disconnects under pressure
- ★ Robust construction for longevity
- ★ Seals readily accessible for easy replacement
- ★ Supplied with Caps and Plugs to protect the thread and help prevent the ingress of contaminants



### MATERIALS

Zinc plated carbon steel body with Viton seals and PTFE backing rings.

### ORDER CODES

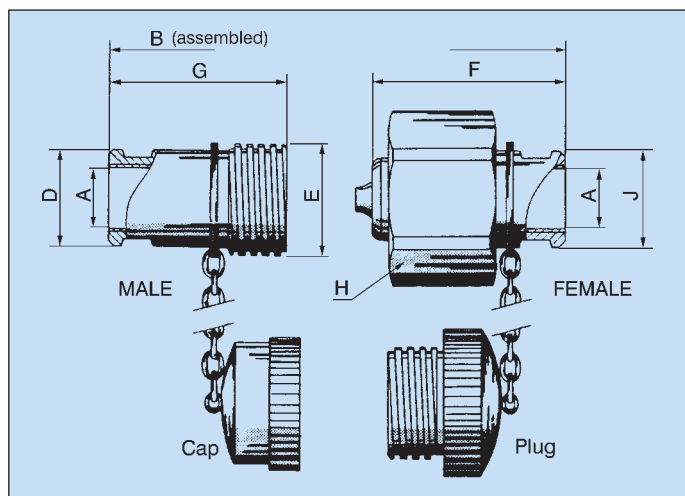
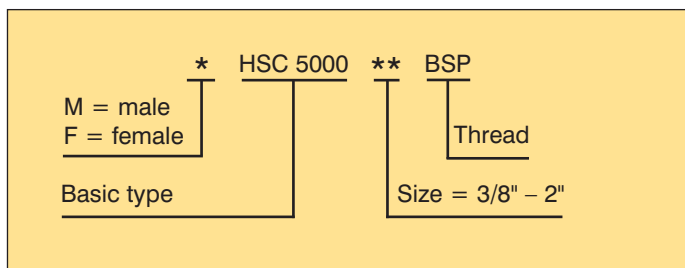

### TECHNICAL DATA

Type and Size	Flow area mm <sup>2</sup>	A	B	D	EØ	F	G	H	J	Weight Female kg	Weight Male kg	Max Flow litres/min	Working pressure bar
HSC 5000 38	45	3/8"	110	30	35.57	55	77	45	27	0.37	0.35	26	500
HSC 5000 12	95	1/2"	135	35	39.64	70	95	50	30	0.53	0.53	52	450
HSC 5000 34	150	3/4"	142	40	44.80	73	99	55	35	0.67	0.72	85	400
HSC 5000 100	250	1"	156	46	57.52	82	106	70	52	1.23	1.25	150	350
HSC 5000 114	370	1 1/4"	171	60	65.55	88	118	80	55	1.92	1.70	230	320
HSC 5000 112	500	1 1/2"	172	68	74.61	86	121	87	62	2.26	2.20	340	300
HSC 5000 200	980	2"	240	90	108.05	120	165	130	85	7.30	6.30	630	250

Dimensions in mm except where stated otherwise.

Do not exceed maximum flow rating as this will invalidate the warranty and may cause seal damage.

## HOLMBURY LTD

Tower House, Vale Rise, Tonbridge, Kent TN9 1TB, ENGLAND

Tel: 01732 357333 Fax: 01732 357666 sales@holmbury.com www.holmbury.com



Certificate No. 15401