

HCV SERIES

2 & 3 WAY HIGH PRESSURE BALL VALVES

INTRODUCTION

Holmbury HCV ball valves are designed to suit a wide range of applications including mobile plant and industrial equipment. Standard valves are intended for use on hydraulic mineral oil. Stainless steel valves are available for use in corrosive environments and/or operation with corrosive fluids.

These valves should not be used as flow control valves and should therefore always be fully open or fully closed.

GENERAL DESIGN

The floating ball is held between two pre-compressed seals which ensure a tight, non-leak fit at both positive and negative pressures. The ball's rotational angle is constrained by a stop pin and disc.

Cranked handles are incorporated to provide good clearance for the operators hands.

Flat handles can be provided on request.

FEATURES

- ◆ Full bore valves provide an unrestricted flow path for negligible pressure drop.
- ◆ Floating ball on pre-compressed seals minimises wear and provides an excellent seal at positive and negative pressures.
- ◆ High working pressures - see table on page 59.
- ◆ Operating temperatures from -20°C to +100°C.
- ◆ Open to close in 1/4 turn (90°).



HCV SERIES, HIGH PRESSURE, BALL VALVES

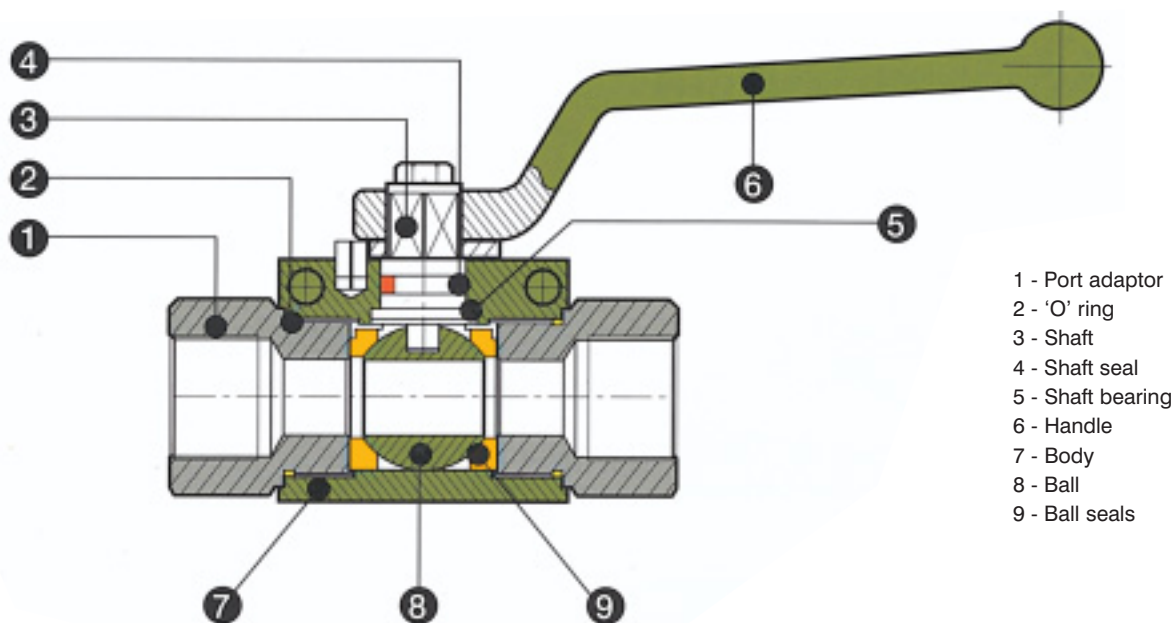

- 1 - Port adaptor
- 2 - 'O' ring
- 3 - Shaft
- 4 - Shaft seal
- 5 - Shaft bearing
- 6 - Handle
- 7 - Body
- 8 - Ball
- 9 - Ball seals

MATERIALS

Standard Specification

- ◆ Body and port adaptor are zinc plated steel (38SMn PB 10).
- ◆ Handle - steel forging, zinc plated.
- ◆ Ball - carbon steel.
- ◆ Ball seals - DELRIN (polyacetalic resin)
- ◆ Shaft seal - nitrile

Special Options

- Body and ball in stainless steel.
- Ball and shaft seal in PTFE.
- DIN 2353 light and heavy.
- Other seals available on request.
- Full bore valves available above 1".

STAINLESS STEEL VALVES

Body and ball in 316 stainless steel for use in the food, chemical and pharmaceutical industries. A variety of special seals can be provided to comply with the stringent specifications required by these applications. For further details contact Holmbury Sales Dept.

ORDER CODES

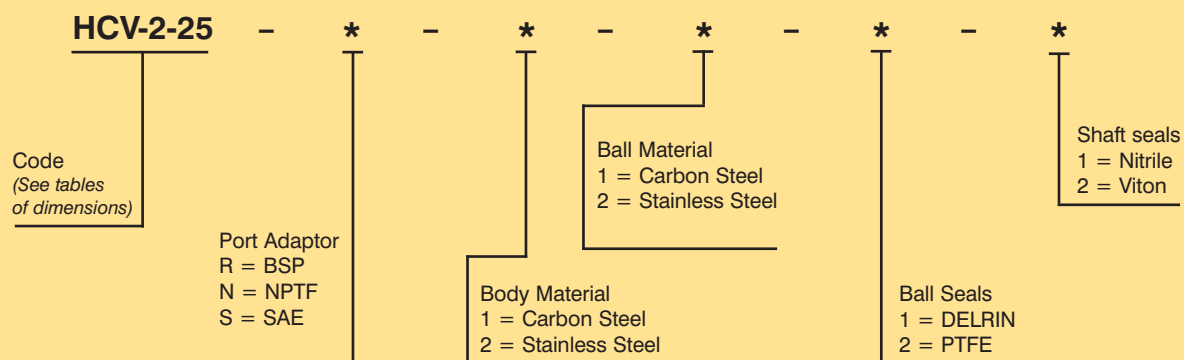

2 WAY BALL VALVES

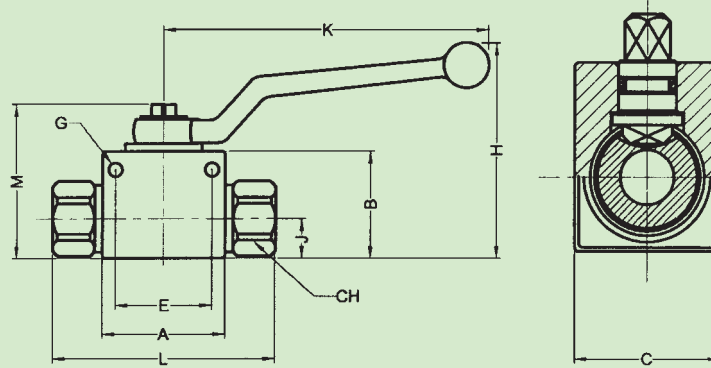

Size	Code	ND	Max. W.P. bar	Thread	A	B	C	E	CH	G	H	J	K	L	M
1/4"	HCV-2-6	6	500	BSP	40	35	26	31.5	22	4.5	71	13	105.5	72.6	45.5
3/8"	HCV-2-10	10	500	BSP	45	40	32	31.5	27	5.2	76	16	105.5	75.4	50.5
1/2"	HCV-2-13	13	500	BSP	50	45	35	38.5	30	6.5	81	17.5	105.5	84.5	55.5
3/4"	HCV-2-20	20	350	BSP	60	58	50	48.5	41	6.5	108	23	159.5	93.4	73
1"	HCV-2-25	25	350	BSP	65	65	57	50.5	46	8.5	115	27.5	159.5	114.5	80
1 1/4"	HCV-2-25	25	350	BSP	80	85	78	*	50	*	135	41	159.5	110	100
1 1/2"	HCV-2-25	25	350	BSP	85	95	85	*	65	*	145	44.5	159.5	120	110
1 1/4"	HCV-2-32	32	320	BSP	80	85	78	*	55	*	135	41	159.5	110	100
1 1/2"	HCV-2-40	40	320	BSP	85	95	85	*	65	*	145	44.5	159.5	120	110
2"	HCV-2-50	50	320	BSP	100	110	100	*	80	*	160	52	159.5	140	125

*Mounting holes not provided

2 WAY BALL VALVES WITH SCREW NECK

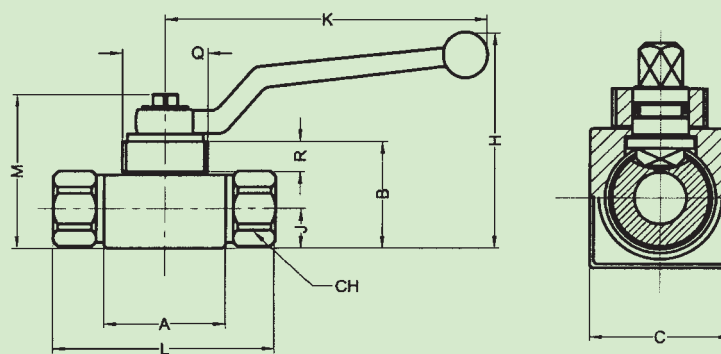

Size	Code	ND	Max. W.P. bar	Thread	A	B	C	R	CH	H	J	K	L	M	Q
1/4"	HCV-2SN-6	6	500	BSP	40	35	26	8	22	71	13	105.5	72.6	45.5	M26 x 150
3/8"	HCV-2SN-10	10	500	BSP	45	40	32	8	27	81	16	105.5	75.4	50.5	M32 x 150
1/2"	HCV-2SN-13	13	500	BSP	50	45	35	10	30	108	17.5	105.5	84.5	55.5	M32 x 150
3/4"	HCV-2SN-20	20	350	BSP	60	58	50	12	41	115	23	159.5	93.4	73	M45 x 150
1"	HCV-2SN-25	25	350	BSP	65	65	57	12	46	135	27.5	159.5	114.5	80	M45 x 150
1 1/4"	HCV-2SN-25	25	350	BSP	80	85	78	12	50	135	41	159.5	110	100	M45 x 150
1 1/2"	HCV-2SN-25	25	350	BSP	85	95	85	12	65	145	44.5	159.5	120	110	M45 x 150

3 WAY BALL VALVES

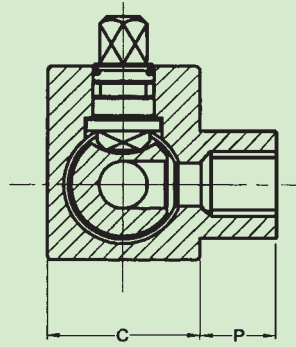
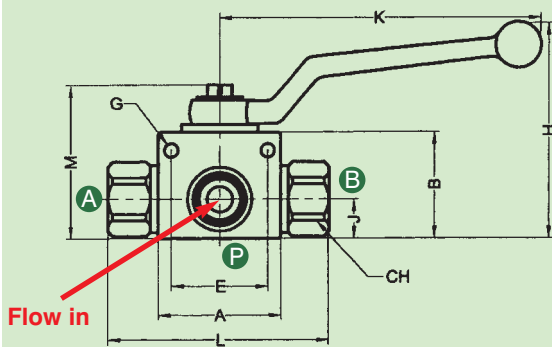

L PORT

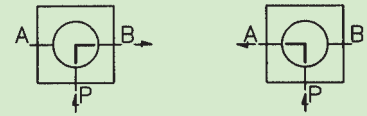

T PORT

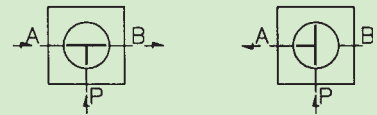

Size	Code	ND	Max. W.P. bar	Thread	A	B	C	E	CH	G	H	J	K	L	M	P
1/4"	HCV-3-6	6	500	BSP	40	35	26	31.5	22	4.5	71	13	105.5	72.6	45.5	13
3/8"	HCV-3-10	10	500	BSP	45	40	32	31	27	4.5	76	16	105.5	75.4	50.5	15
1/2"	HCV-3-13	13	500	BSP	50	45	35	38.5	30	6.5	81	17.5	105.5	84.5	55.5	17.5
3/4"	HCV-3-20	20	350	BSP	60	58	50	48.5	41	6.5	108	23	159.5	93.4	73	19
1"	HCV-3-25	25	350	BSP	65	65	57	50.5	46	8.5	115	27.5	159.5	114.5	80	25
1 1/4"	HCV-3-25	25	350	BSP	80	85	78	*	50	*	135	41	159.5	110	100	28
1 1/2"	HCV-3-25	25	350	BSP	85	95	85	*	65	*	145	44.5	159.5	120	110	28

*Mounting holes not provided

NOTE: 'L' ported valves are standard. 'T' ported valves available on request

3 WAY BALL VALVES WITH SCREW NECK

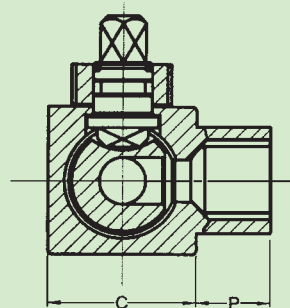
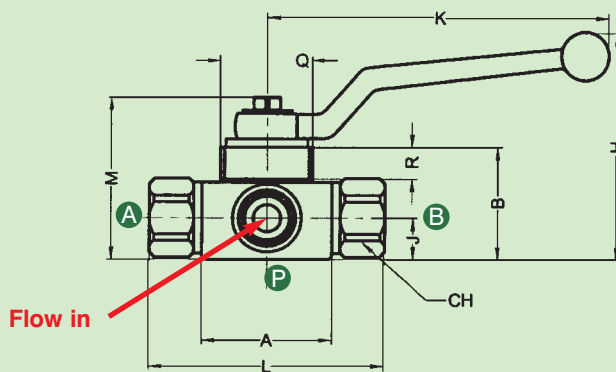

Size	Code	ND	Max. W.P. bar	Thread	A	B	C	R	CH	H	J	K	L	M	P	Q
1/4"	HCV-3SN-6	6	500	BSP	40	35	26	8	22	71	13	105.5	72.6	45.5	14	M26 x 150
3/8"	HCV-3SN-10	10	500	BSP	45	40	32	8	27	76	16	105.5	75.4	50.5	14	M32 x 150
1/2"	HCV-3SN-13	13	500	BSP	50	45	35	10	30	81	17.5	105.5	84.5	55.5	17	M32 x 150
3/4"	HCV-3SN-20	20	350	BSP	60	58	50	12	41	108	23	159.5	93.4	73	20	M45 x 150
1"	HCV-3SN-25	25	350	BSP	65	65	57	12	46	115	27.5	159.5	114.5	80	24	M45 x 150
1 1/4"	HCV-3SN-25	25	350	BSP	80	85	78	12	50	135	41	159.5	110	100	28	M45 x 150
1 1/2"	HCV-3SN-25	25	350	BSP	85	95	85	12	65	145	44.5	159.5	120	110	28	M45 x 150

All dimensions shown are for guidance only. If critical please contact Holmbury Technical Department